

Overview and Identification

The Submersible Duct Unit is for duct mounting and temperature measurement of air across cooling coils or wet locations. The Stainless Steel probe tip is very small (1/8") to fit between coil fins and made in different lengths for a custom duct fit.

The unit is available in multiple thermistor or RTD types as shown in the specifications. Enclosure mounting styles come in plastic or metal for both NEMA 1 and NEMA 4 applications and are all plenum rated.

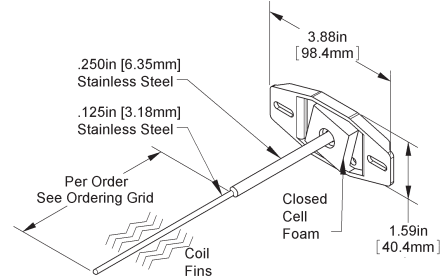

Fig 1: Duct Unit with No Box (NB)

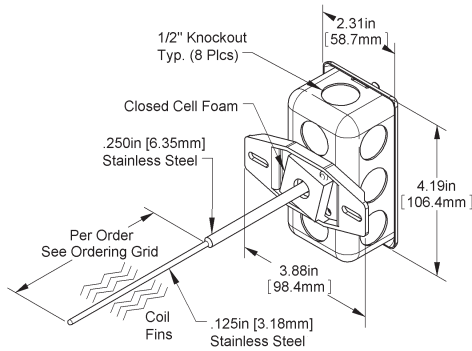

Fig 2: Duct Unit with J-Box (Standard)

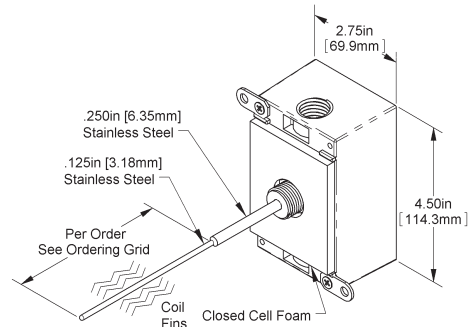

Fig 3: Weatherproof (WP) Duct Unit

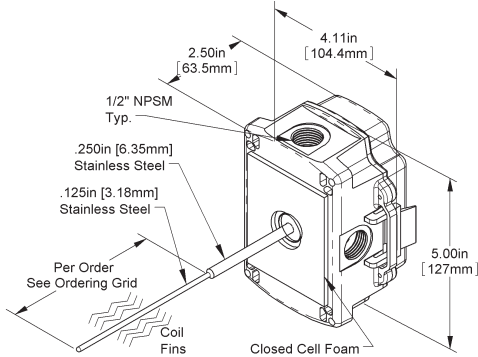

Fig 4: BAPI-Box (BB) Duct Unit

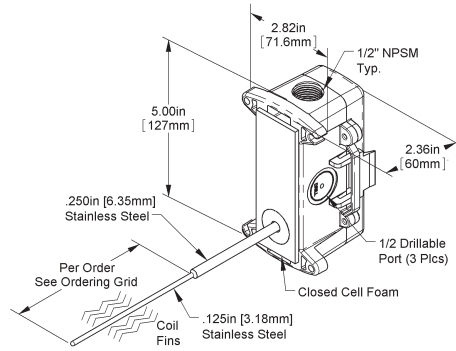

Fig 5: BAPI-Box 2 (BB2) Duct Unit

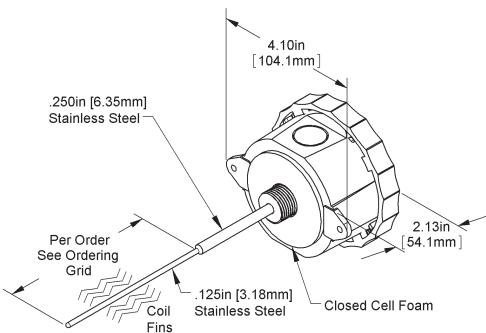

Fig 6: Weather Tight Enclosure (EU) Duct Unit

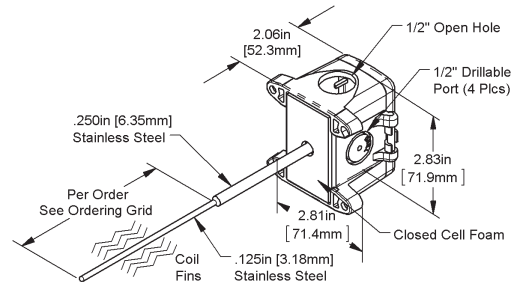

Fig 7: BAPI-Box 4 Enclosure (BB4) Duct Unit

(A Pierceable Knockout Plug is available from BAPI for the open port in the BB4. Part #BA/PKP-100)

Mounting

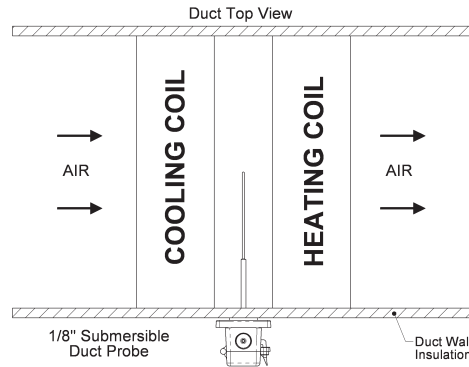

Fig 8: Cooling Coil Discharge Air Temperature Application

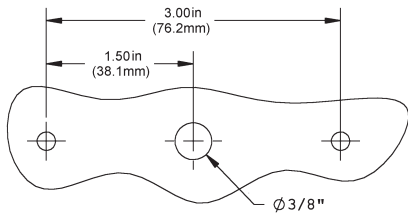

Fig 9: Junction Box or No Box (NB) Mounting Holes

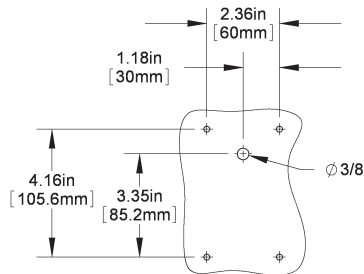
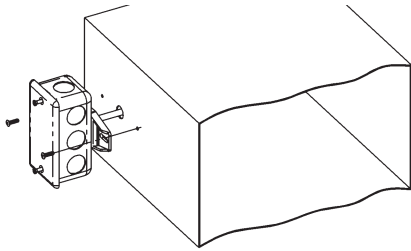

Fig 10: BAPI-Box 2 (BB2) Enclosure Mounting Holes

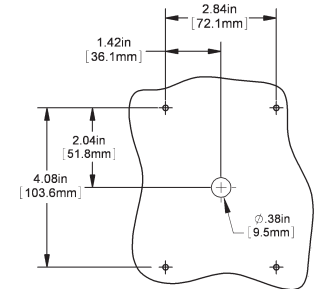
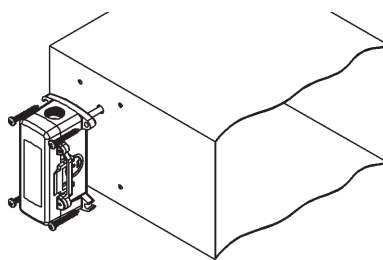

Fig 11: BAPI-Box (BB) Enclosure Mounting Holes, Rotate 90° for Horizontal Mounting

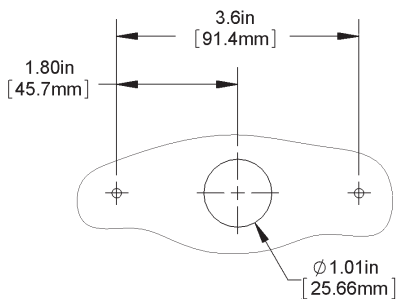
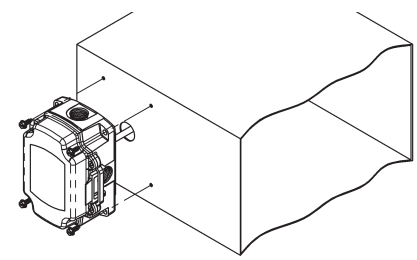

Fig 12: Weather Tight (EU or EUO) Enclosure Mounting Holes

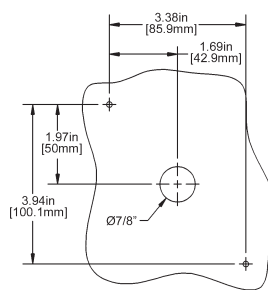
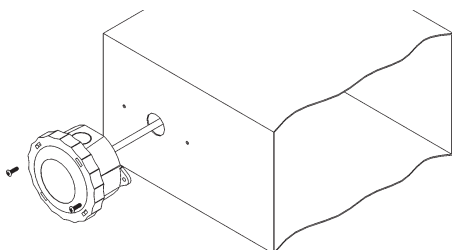

Fig 13: Weatherproof (WP) Enclosure Mounting Holes

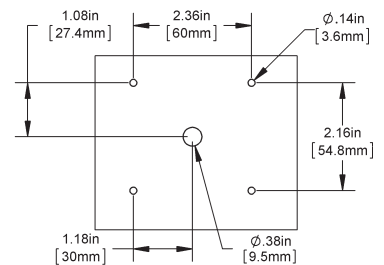
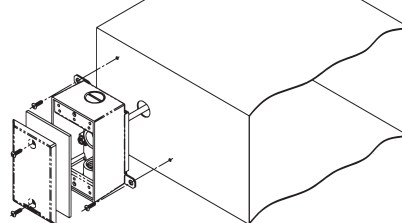
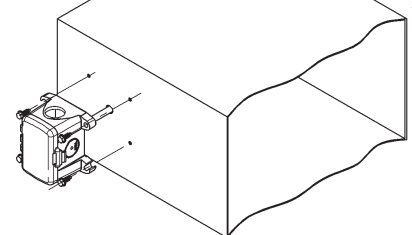

Fig 14: BAPI-Box 4 (BB4) Enclosure Mounting Holes



Specifications subject to change without notice.

Wiring & Termination

BAPI recommends using twisted pair of at least 22AWG and sealant filled connectors for all wire connections. Larger gauge wire may be required for long runs. All wiring must comply with the National Electric Code (NEC) and local codes. Do NOT run this device's wiring in the same conduit as high or low voltage AC power wiring.

BAPI's tests show that inaccurate signal levels are possible when AC power wiring is present in the same conduit as the sensor wires.

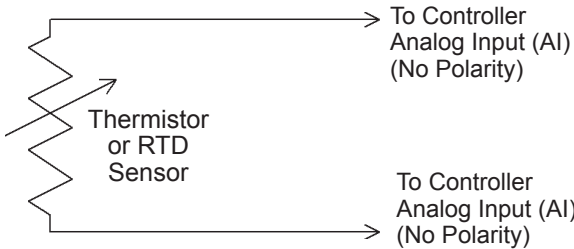

Fig. 15: 2 Wire Lead Wire Termination for Thermistor or RTD

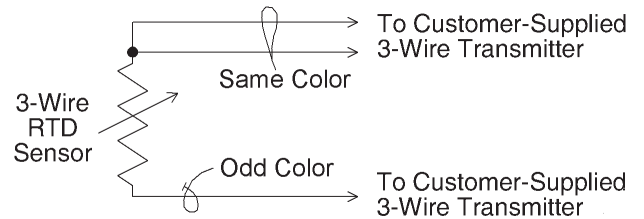

Fig. 16: 3 Wire Lead Wire Termination for RTD

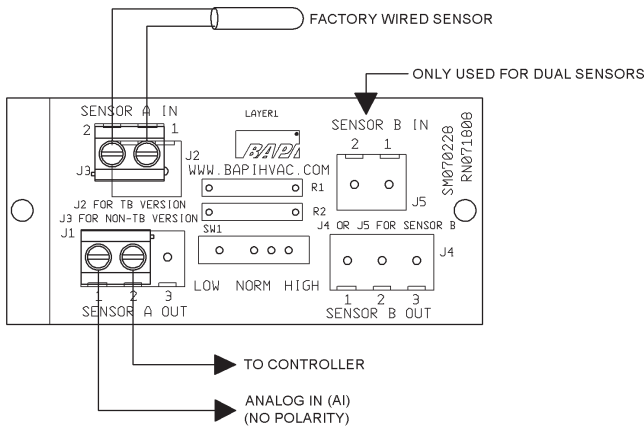

Fig. 17: Terminal Strip (-TS) Option for 2 Wire Sensors Termination

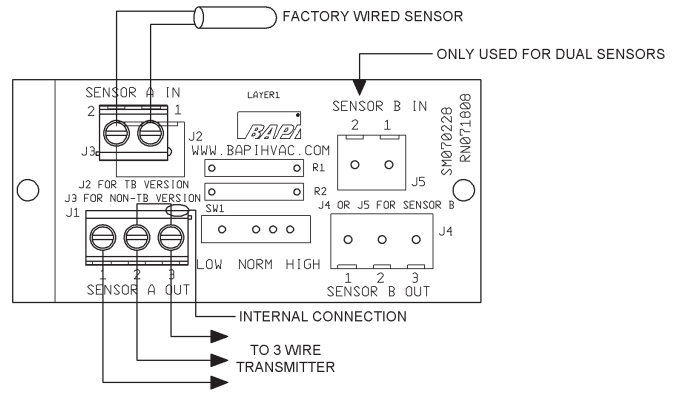

Fig. 18: Terminal Strip (-TS) Option for 3 Wire Sensors Termination

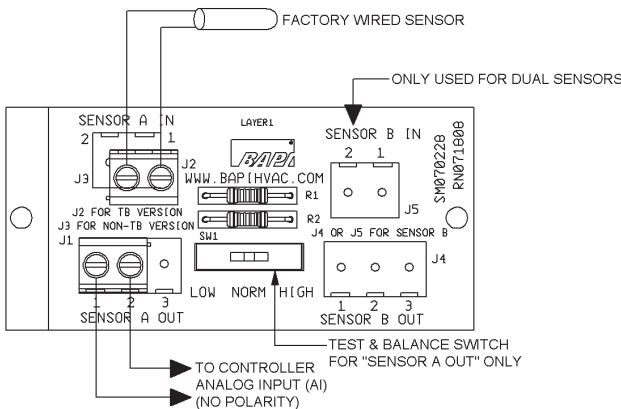

Fig. 19: Test & Balance (-TB) Option for 2 Wire Sensors Termination

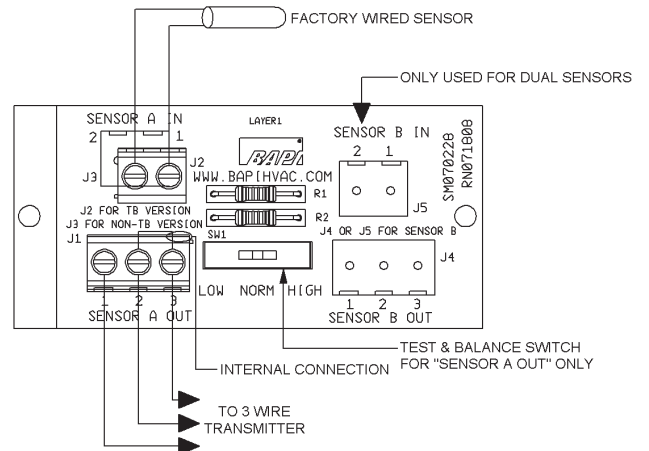

Fig. 20: Test & Balance (-TB) Option for 3 Wire Sensors Termination



Diagnosics

Problems:

Controller reports higher or lower than actual temperature

Possible Solutions:

- Confirm the input is set up correctly in the front end software
- Check wiring for proper termination & continuity. (shorted or open)
- Disconnect wires and measure sensor resistance and verify the "Sensor" output is correct.

Specifications

Sensor:	Passive	Mounting	Extension tabs (ears), 3/16" holes
Thermistor,	2 wire	Enclosure Types	
RTD,	2 or 3 wire	J-Box	- JB , w/eight 1/2" knockouts
Thermistor	Thermal resistor (NTC)	No Box	- NB , intended for open wiring
Temp. Output	Resistance Per Order1	Weatherproof	- WP , w/ two 1/2" FNPT entries, (Bell box)
Accuracy	(std) ±0.36°F, (±0.2°C)	BAPI-Box	- BB , w/ four 1/2" NPSM & one 1/2" drill-out
Accuracy	(Hi) ±0.18°F, (±0.1°C), [XP] option	BAPI-Box 2	- BB2 , w/ three 1/2" NPSM & three 1/2" drill-outs
Stability	0.036°F/Year, (<0.02°C/Year)	BAPI-Box 4:	- BB4 , w three 1/2" drill-outs & one 1/2" open port
Heat dissipation	2.7 mW/°C	Weather Tight	- EU , - EUO , w/two 1/2" knockouts
Temp. Drift	<0.02°C per year	Enclosure Ratings	
Probe range	-40° to 221°F (-40° to 105°C)	J-Box	- JB , NEMA 1
RTD	Resistance Temp Device (PTC)	No Box	- NB , No rating
Platinum (Pt)	100Ω and 1KΩ @0°C, 385 curve	Weatherproof	- WP , NEMA 3R, IP14
Platinum (Pt)	1KΩ @0°C, 375 curve	BAPI-Box	- BB , NEMA 4X, IP66
Pt Accuracy (Std)	0.12% @Ref, or ±0.55°F, (±0.3°C)	BAPI-Box 2	- BB2 , NEMA 4X, IP66
Pt Accuracy (Hi)	0.06% @Ref, or ±0.277°F, (±0.15°C), [A]option	BAPI-Box 4	- BB4 , IP10 (IP44 with Knockout Plug in the open port)
Pt Stability	±0.25°F, (±0.14°C)	Weather Tight	- EU , NEMA 4X, IP66
Pt Self Heating	0.4 °C/mW @0°C	Weather Tight	- EUO , NEMA 4X, IP66, UV rated
Pt Probe range	-40° to 221°F, (-40 to 105°C)	Enclosure Materials	
Nickel (Ni)	1000Ω @70°F, JCI curve	2x4 J-Box	- JB , Galvanized steel, UL94H-B
Ni Probe range	-40° to 221°F (-40 to 105°C)	No Box	- NB , Nylon 66, UL94H-B
Sensitivity	Approximate @ 32°F (0°C)	Weatherproof	- WP , Cast Aluminum, UV rated
Thermistor	Non-linear – Go to bapihvac.com click "Sensor Specs"	BAPI-Box	- BB , Polycarbonate, UL94V-0, UV rated
RTD (Pt)	3.85Ω/°C for 1KΩ RTD	BAPI-Box 2	- BB2 , Polycarbonate, UL94V-0, UV rated
Nickel (Ni)	0.385Ω/°C for 100Ω RTD	BAPI-Box 4:	- BB4 , Polycarbonate & Nylon, UL94V-0
	2.95Ω/°F for the JCI RTD	Weather Tight	- EU , ABS Plastic, UL94V-0
Lead wire	22awg stranded	Weather Tight	- EUO , ABS Plastic, UL94V-0, UV rated
Insulation	Etched Teflon, Plenum rated	Ambient (Encl.)	0 to 100% RH, Non-condensing
Probe	Stainless Steel, Sheath 0.25" OD, probe 0.125	All BAPI-Boxes	- BB , BB2 , BB4 , -40 to 185°F, (-40 to 85°C)
Probe Length	12" to 48" per order	Weather Tight	- EUO , EU , -40 to 185°F, (-40 to 85°C)
		J-Box & No Box	- JB , NB , -40 to 212°F, (-40 to 100°C)
		Weatherproof	- WP , -40°F to 212°F, (-40° to 100°C)
		Agency	RoHS, *CE PT= DIN43760, IEC Pub 751-1983, JIS C1604-1989 *Passive Thermistors 20KΩ and smaller are CE compliant